

---

# FUTUREENERGY

---

## **Specification**

Futureenergy, 48V 1kW Permanent Magnet Generator

Prepared By

D. Nangle, November 2016

## Contents

Dimensions .....	3
Specification .....	4
Graph: Power vs RPM @ Load Resistances ( $\Omega$ ) .....	5
Graph: Terminal Voltage vs RPM @ Load Resistances .....	6
Graph: Terminal Current vs RPM @ Load Resistances .....	7
Graph: DC Load Voltage vs RPM @ Load Resistances .....	8
Graph: DC Load Current vs RPM @ Load Resistances .....	9
Graph: Open RMS L/L Voltage vs RPM .....	10
Graph: Open DC Voltage vs RPM .....	11
Graph: Fundamental Frequency vs RPM .....	12
Graph: Efficiency vs Current @ 750 RPM Constant .....	13
Graph: Cogging Torque .....	14

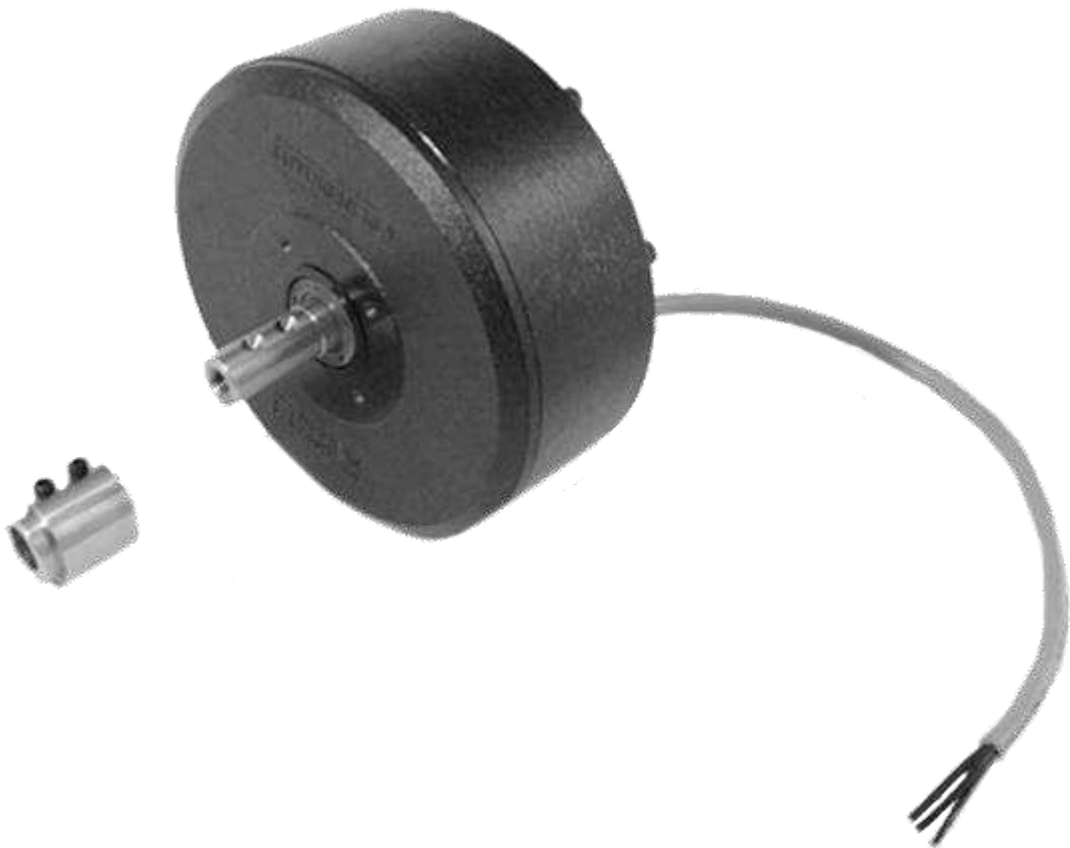

# Dimensions

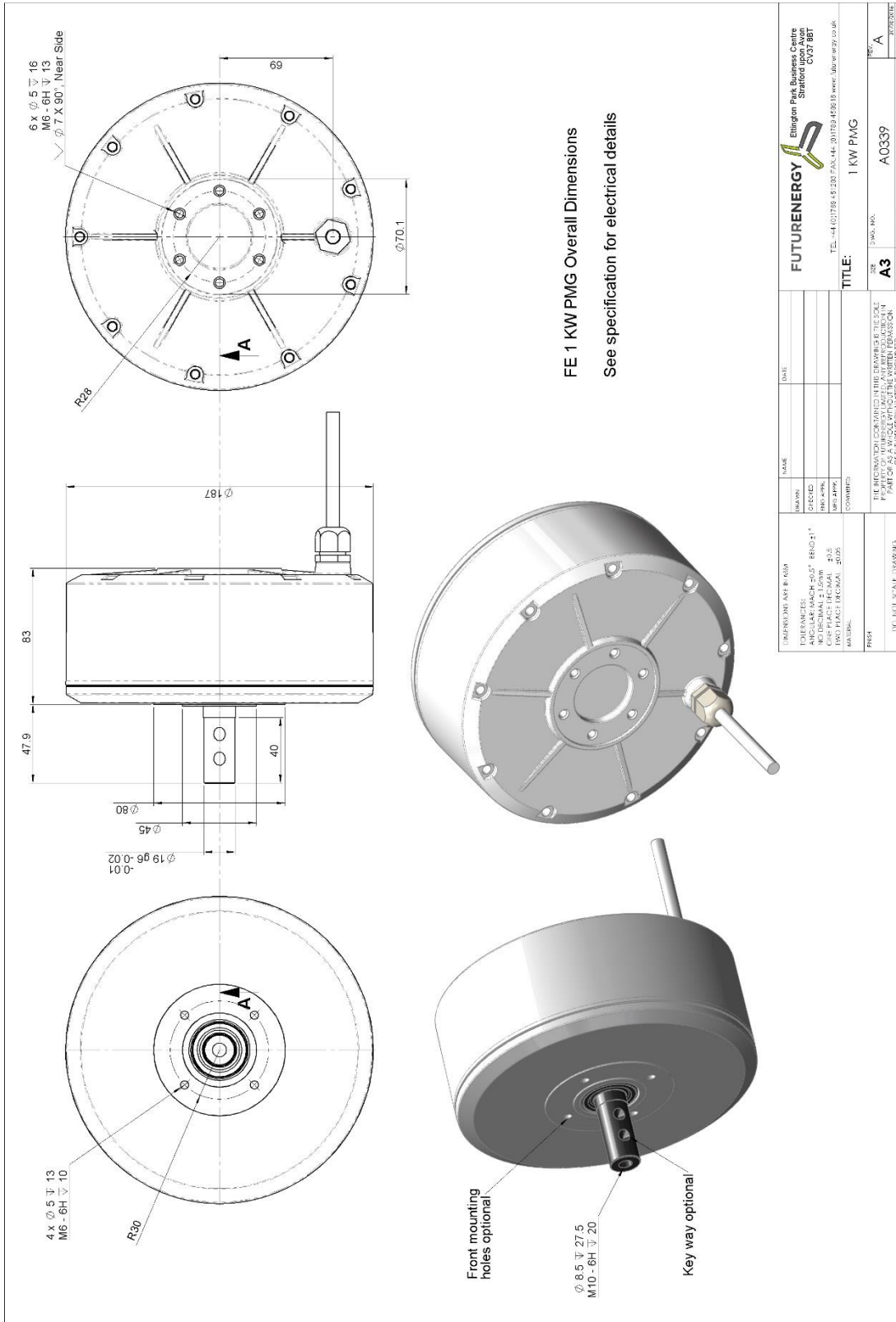

## Specification

<b>Nominal Rated Power</b>	1 kW (@ 6.4 ohms load)
<b>Nominal RPM</b>	800 RPM
<b>Line / Line RMS Open Voltage</b>	68.3V*
<b>Nominal Line Current</b>	10 Amps**
<b>Maximum Current (100% Duty Cycle / Air Cooled 20°C)</b>	20 Amps
<b>Configuration</b>	3 Phase, Star wound AC output
<b>Line / Line Winding Resistance</b>	0.36 Ohms
<b>Nominal Self Inductance</b>	0.7776 mH
<b>Maximum Over-Load Power</b>	1.5 kW
<b>Efficiency</b>	92 %
<b>Maximum Cogging Torque (Excluding Shaft Seals)</b>	< 0.5 Nm
<b>Duty @ Nominal Power</b>	100%
<b>Insulation Class</b>	H
<b>Mounting</b>	Any
<b>Shaft Material</b>	Stainless Steel
<b>Magnet Material</b>	NdFeB
<b>Shell Material</b>	LM25 Aluminium
<b>Protection</b>	IP54
<b>Poles</b>	12
<b>Winding code</b>	P123-T20-W1.5

\* DC Voltage requires an additional bridge rectifier

\*\* Voltage and current will depend on connected electrical system. For example; a system charging 48V battery bank will reduce generator voltage to the battery charge voltage and increase current. Values quoted assume fixed resistance loads.

## Graph: Power vs RPM @ Load Resistances ( $\Omega$ )

Power v RPM at load resistance

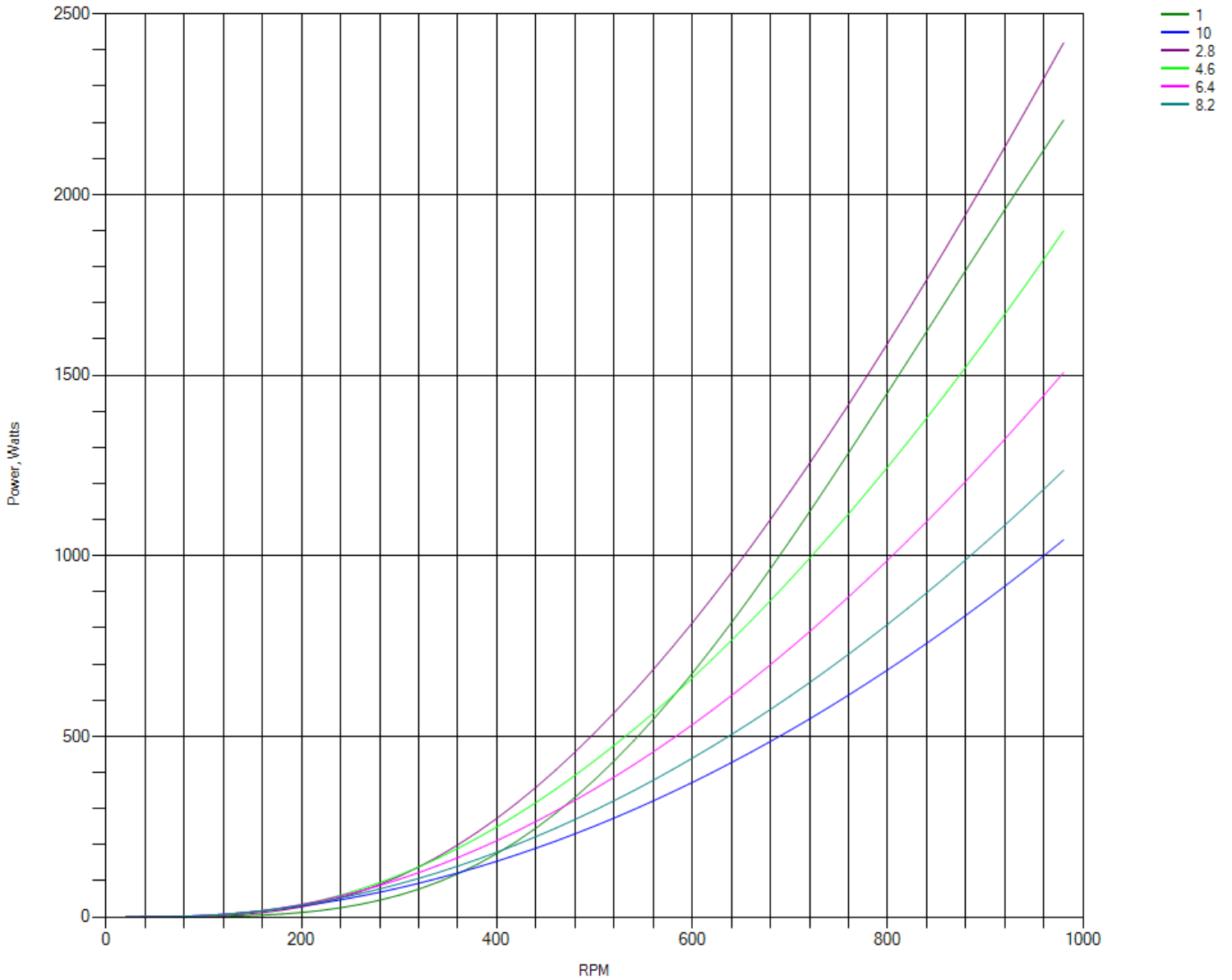

## Graph: Terminal Voltage vs RPM @ Load Resistances

### Terminal Voltage v RPM at load resistance

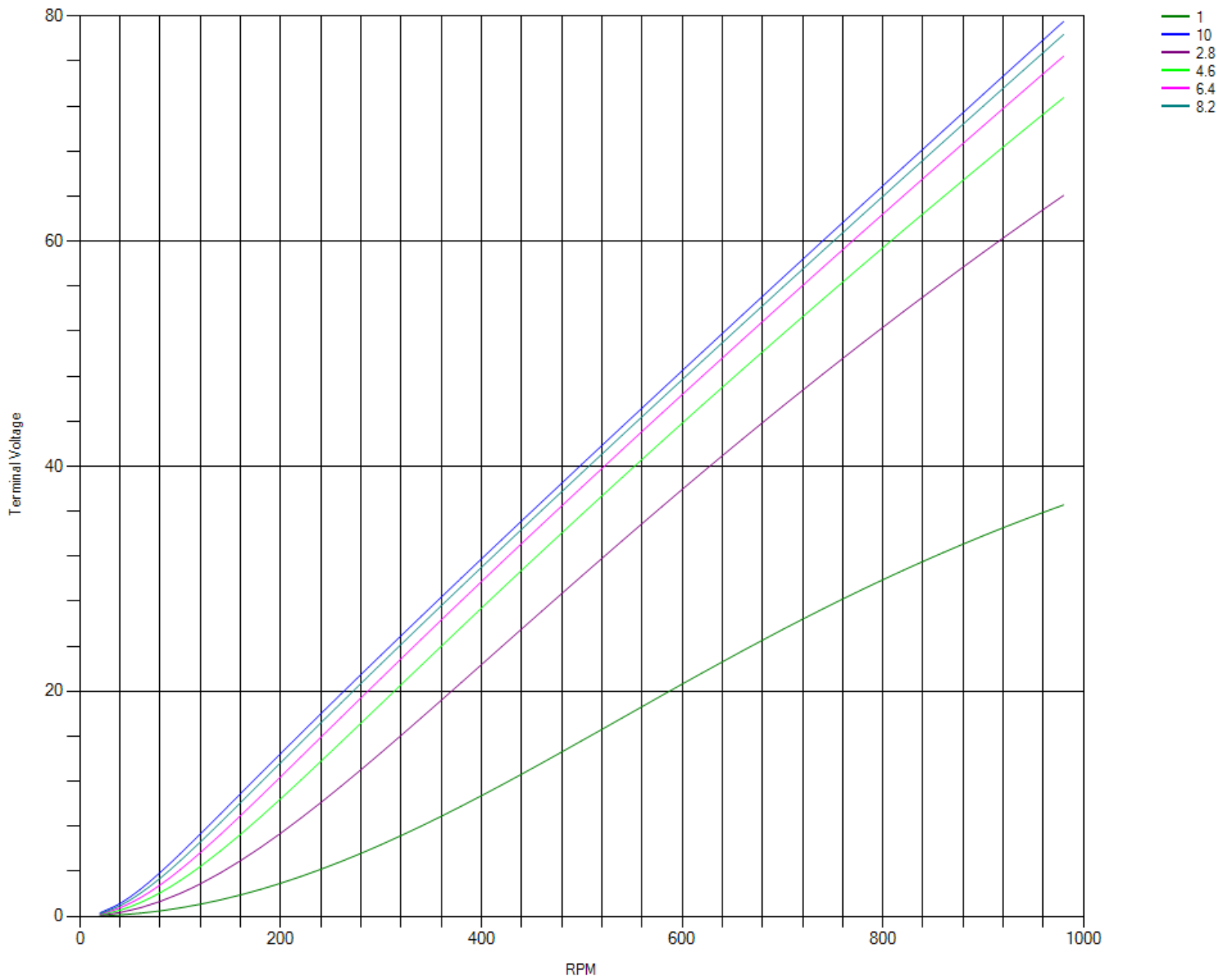

## Graph: Terminal Current vs RPM @ Load Resistances

Terminal Current v RPM at load resistance

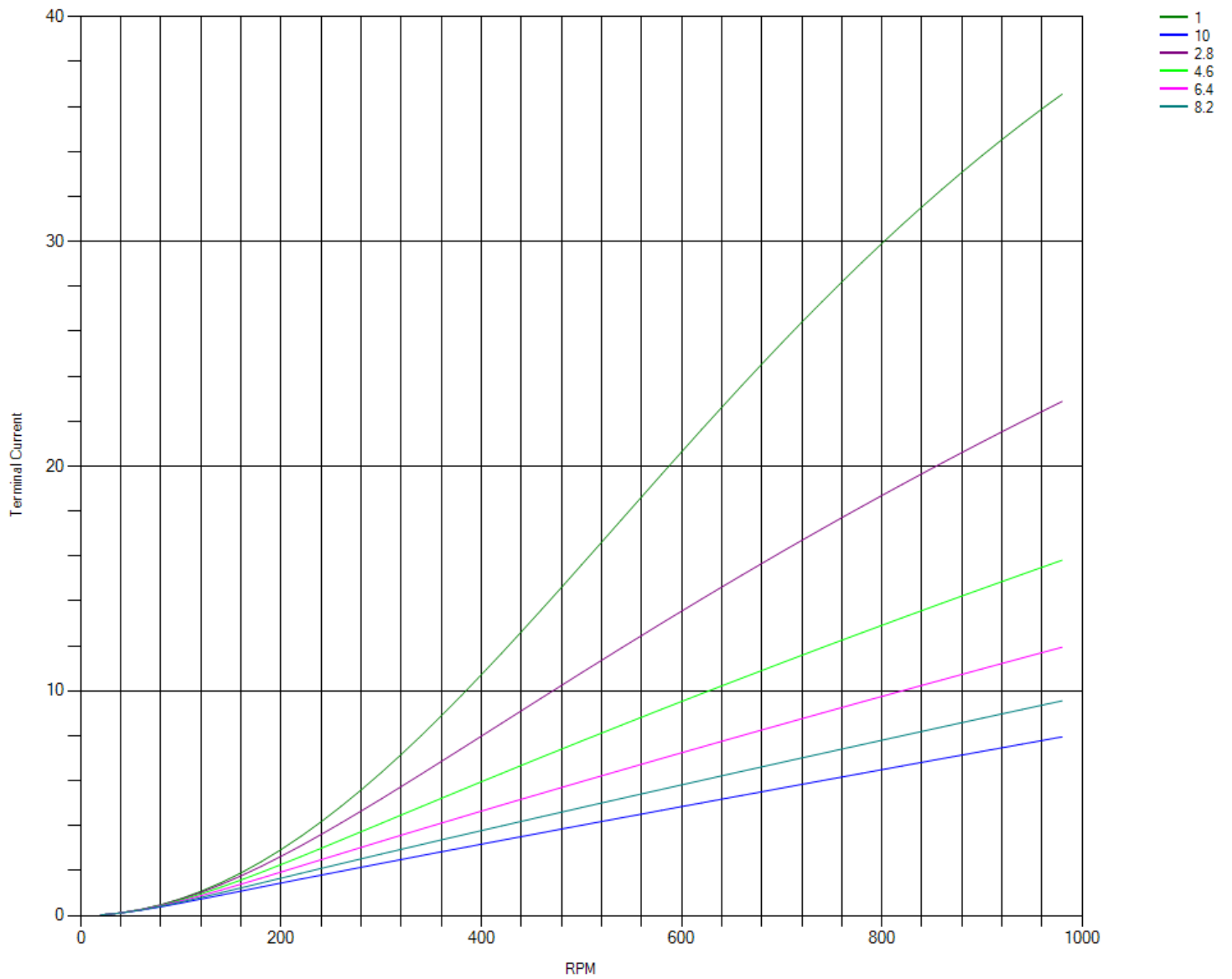

## Graph: DC Load Voltage vs RPM @ Load Resistances

### DC Load Voltage v RPM at load resistance

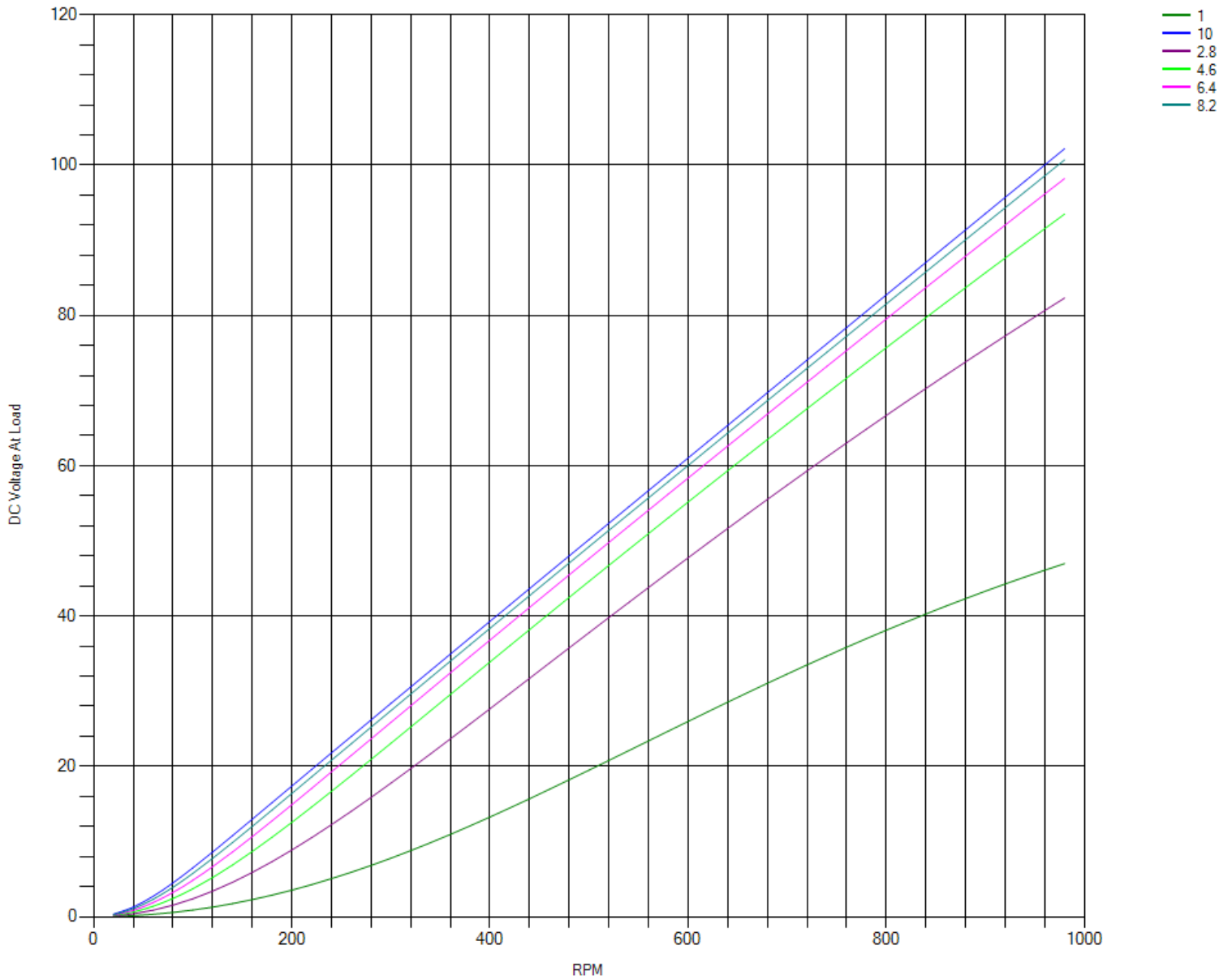



## Graph: DC Load Current vs RPM @ Load Resistances

### DC Load Current v RPM at load resistance

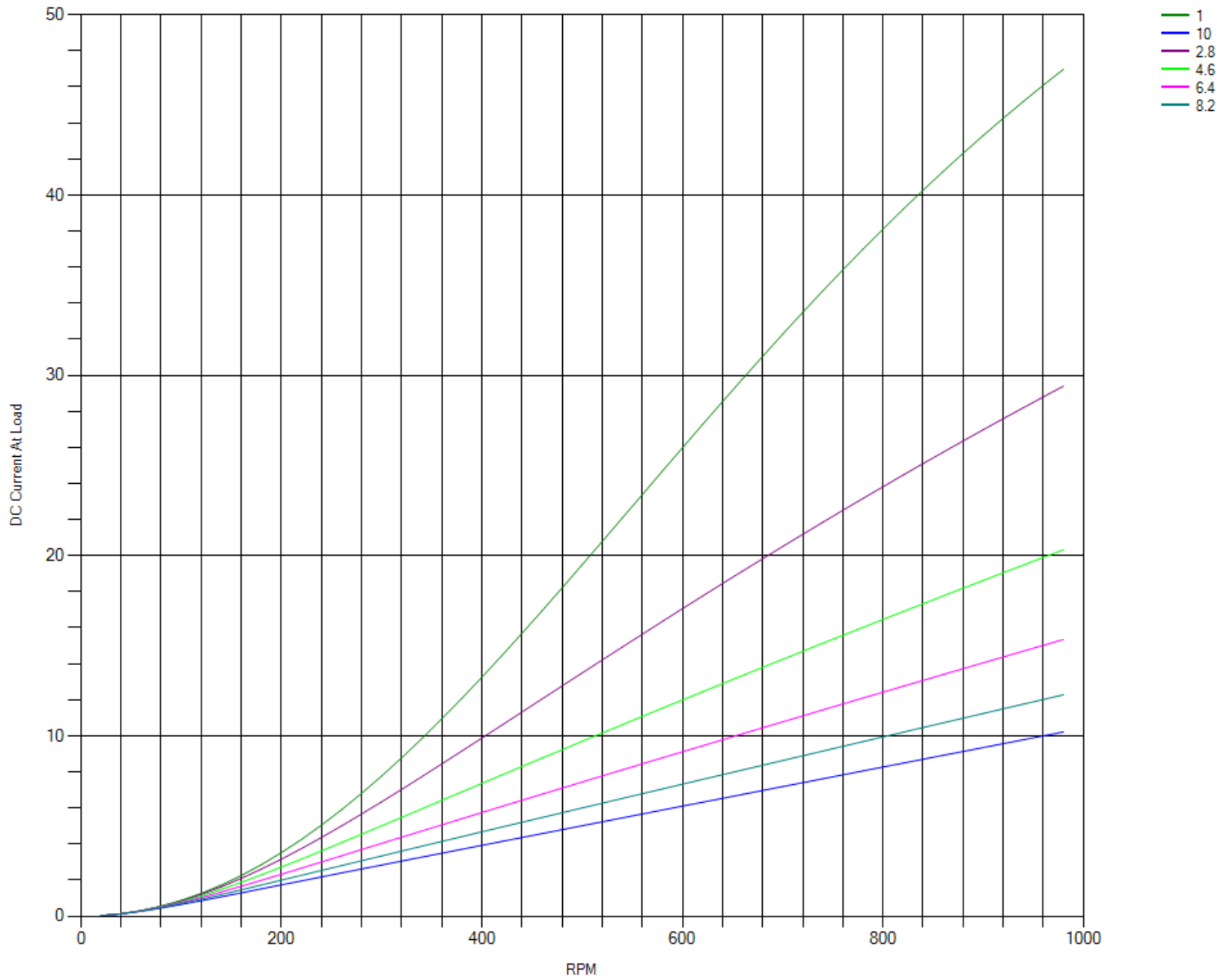

## Graph: Open RMS L/L Voltage vs RPM

Open Line / line Voltage With No Load

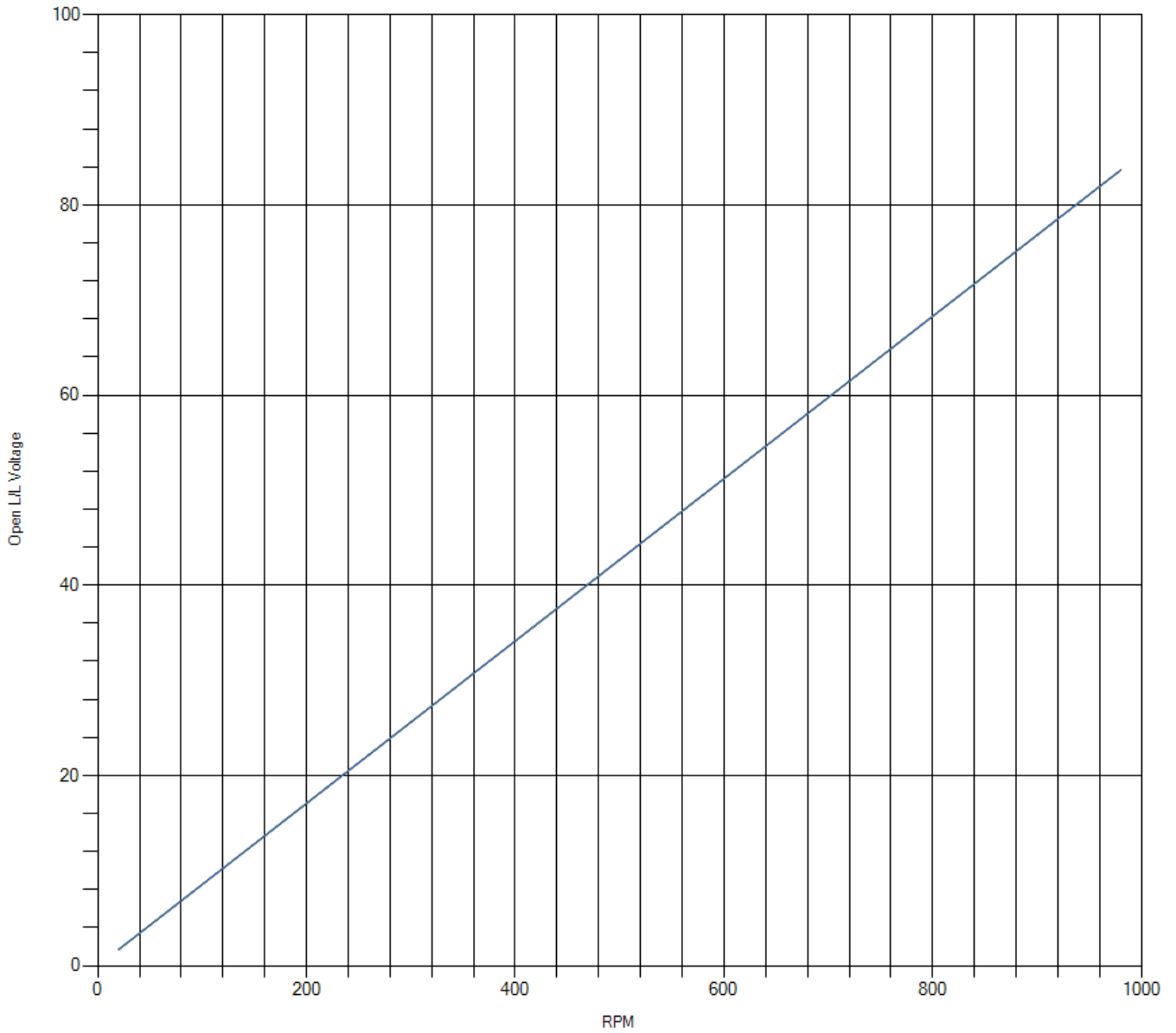

## Graph: Open DC Voltage vs RPM

Open DC Voltage With No Load

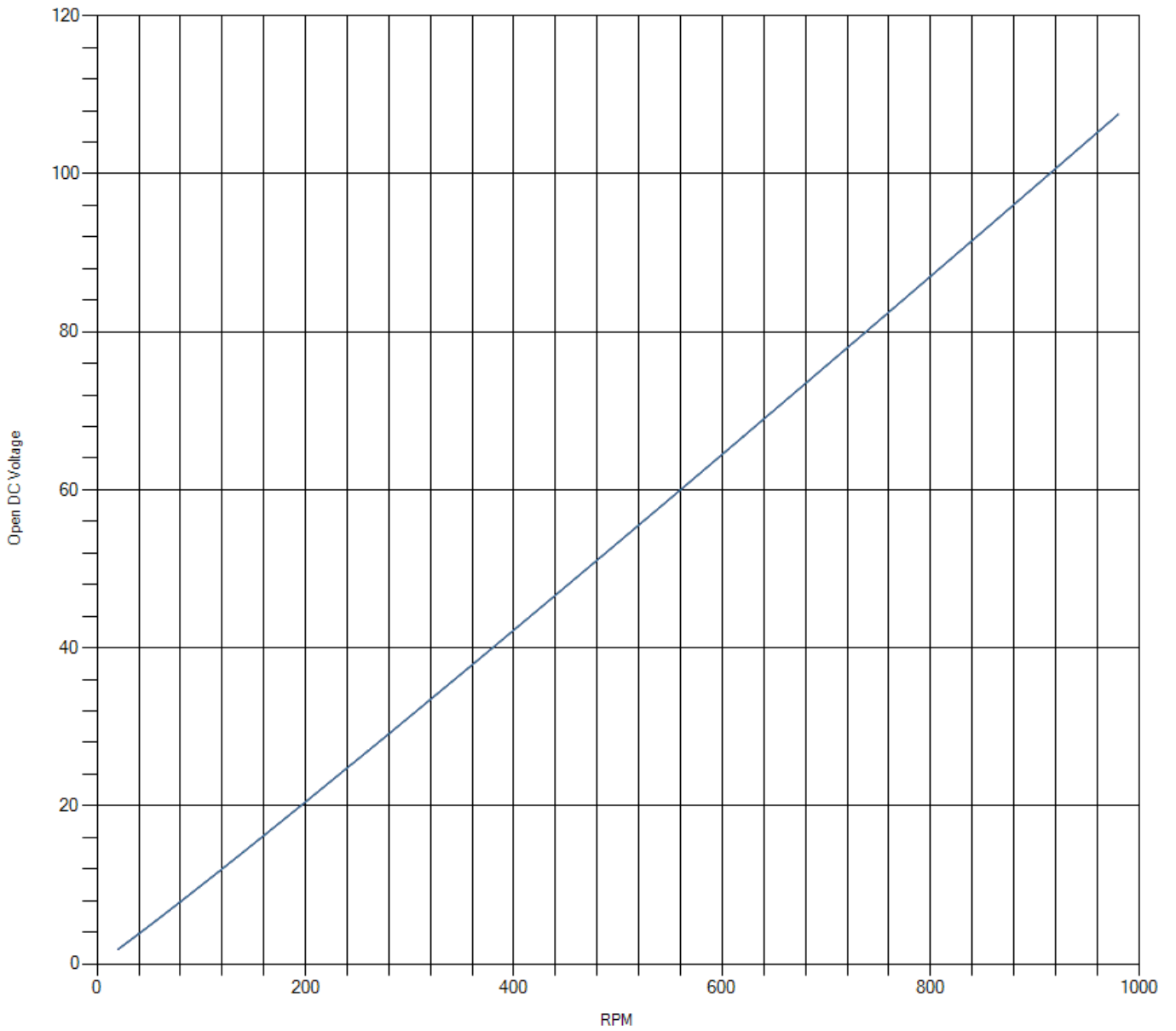

## Graph: Fundamental Frequency vs RPM

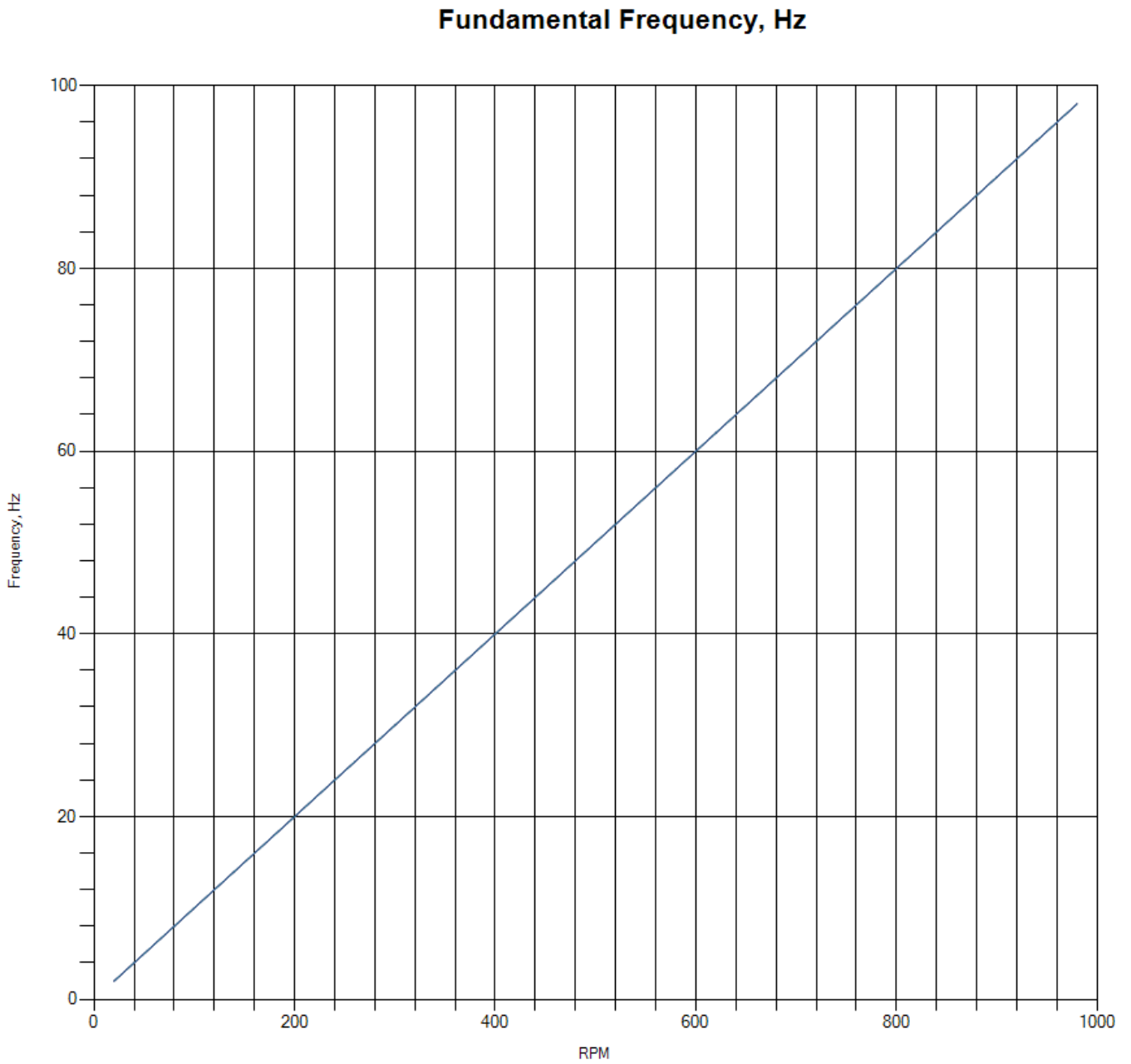

Graph: Efficiency vs Current @ 750 RPM Constant

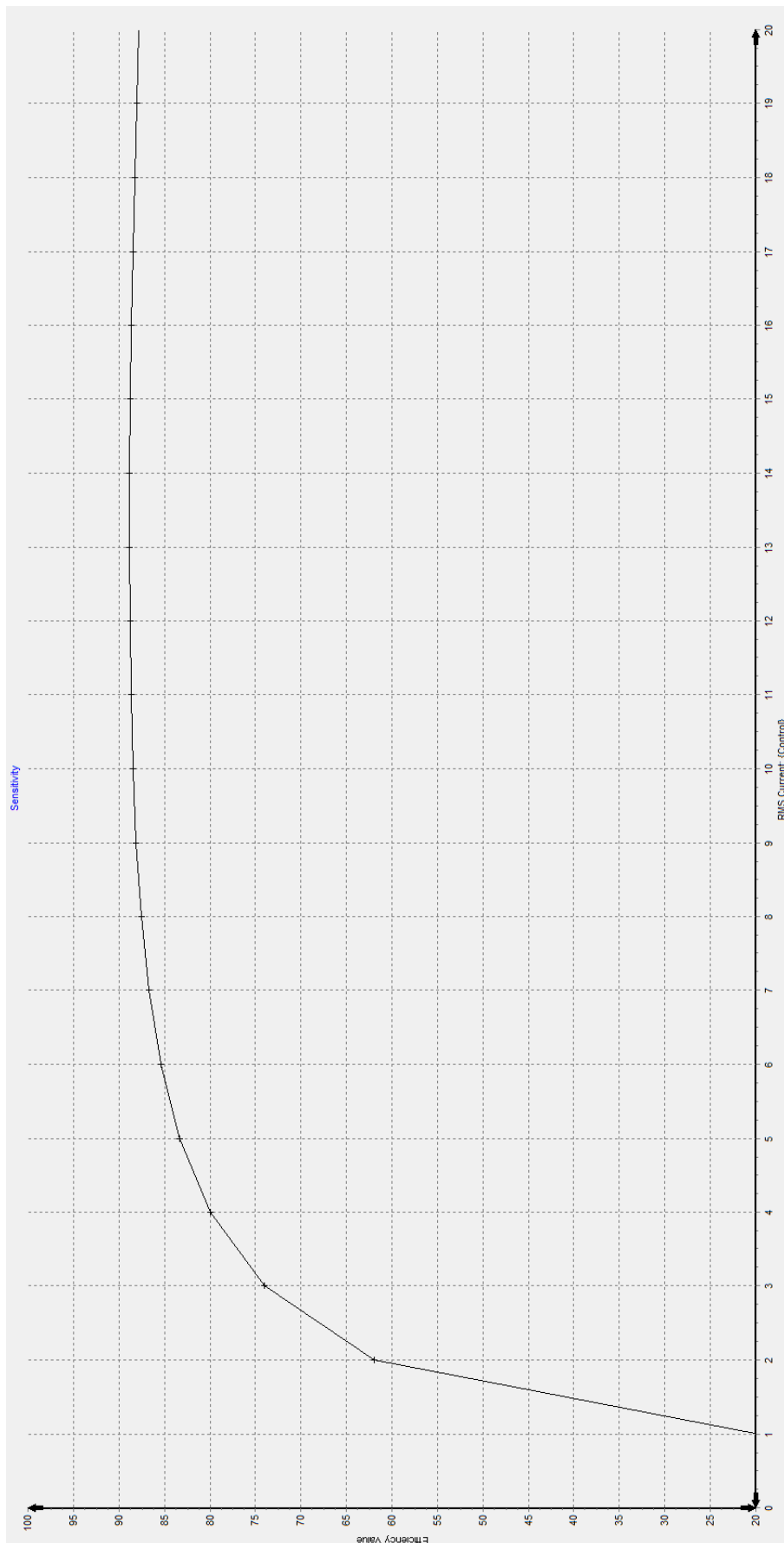

# Graph: Cogging Torque

